

ZAXIS-6 series

HITACHI

Reliable Solutions

ZAXIS48U



HYDRAULIC EXCAVATOR

Model code : ZX48U-6

Engine rated power : 29.1 kW (ISO 14396 : 2002)

Operating weight : Cab 4 850 – 5 180 kg

Bucket ISO heaped : 0.11 – 0.14 m³

ZX48U-6

The efficient excavator



6. Enhanced performance



8. Exceptional comfort



10. Easy to maintain

No compromise





Perfect fit

The ZX48U-6 has been designed to enhance productivity on a variety of job sites, including utilities, foundation work, landscaping, and indoor demolition and construction. Equipped with a powerful Stage V-compliant engine and muffler filter after-treatment device, it benefits from reduced fuel costs and emissions. Also suitable for rental projects, the ZX48U-6 is easy to operate and maintain, and offers an exceptionally comfortable working environment.



Power-assist front window

Front window opens smoothly and easily.



Improved performance

The long blade enhances efficiency.



Short-tail swing radius

The short-tail swing radius of the ZX48U-6 is ideal for confined spaces.



Comfortable cab

The wide operator seat, adjustable and softer arm rest and easy access to the pressurised cab provide a comfortable work space.



Enhanced durability

LED lights on the cab and boom last longer than halogen alternatives.



Improved safety

Rear wiper improves visibility and safety.



Air ventilation

Improves heating efficiency by 17% and rear defrosting function aids visibility in cold weather conditions. Cooling efficiency improved by up to 6%.



Smooth operation

The auxiliary function lever ensures excellent control of attachments.



Easy maintenance

Components are easily accessible.

Enhanced performance

Thanks to the short-tail swing radius of the ZX48U-6, it is the perfect fit for urban job sites where space is often limited. Fast, powerful and fuel-efficient, it will ensure high levels of productivity, and performs with lower levels of fuel consumption and fewer emissions than previous models.

Efficient productivity

The ZX48U-6 delivers high levels of productivity on the job site thanks to a powerful Stage V-compliant engine, quick cycle time and an efficient hydraulic system. The EGR and muffler filter reduce NOx and particulate matter, and a common rail system helps the engine to run optimally. This not only reduces emissions, but also contributes to greater fuel efficiency and reduced running costs.

Built to last

Durable features of the ZX48U-6 – such as strengthened front joints, improved swing post and boom cylinder guard – ensure a reliable performance, helping you to get the job done on time and on budget.

Lower fuel costs

The advanced energy-saving system combines ECO mode, auto idle and isochronous control features to significantly reduce fuel consumption. It also reduces noise levels and emissions.

Remote monitoring

ConSite Pocket and ConSite Shot apps (optional) provide maintenance and machine operational information. Global e-Service gives access to location information and operational data such as fuel, hours meter, engine data and more.



Durable features contribute to a reliable performance.



Quick cycle time and efficient hydraulics ensure high productivity.



Multifunctional LCD monitor shows data at a glance.



A clear view from the cab.



LED lights have a longer lifetime than halogen alternatives.



Exceptional comfort

The spacious, air-conditioned cab of the ZX48U-6 has been designed to make the operator feel at ease during the working day. It offers excellent visibility of the job site, and several user-friendly features to ensure easy and safe operation.

Spacious cab

The ROPS-compliant cab of the ZX48U-6 is spacious and easy to access via the entrance step. Fitted with a wide and adjustable sliding suspension seat, folding foot pedals and adjustable arm rest, the ZX48U-6 provides a high level of comfort for operators.

Easy operation

User-friendly controls are in easy reach of the operator and the hydraulic pilot control levers ensure a smooth operation. The blade is 90mm longer than on the previous model, and the distance between the tip of the bucket and blade is now shorter, which means more material can be gathered and less remains for the operator to clear manually.

Enhanced design

The ZX48U-6 is equipped with new LED lights, which have a longer lifetime than halogen alternatives for efficient energy use. Options include a sun visor on the front window and an auxiliary function lever with proportional switch for easy control of the front attachment.



Controls are within easy reach.

Easy to maintain

Routine maintenance and servicing of the ZX48U-6 can be carried out with minimum effort, resulting in maximum uptime. Components are accessible for inspection and are designed to be easily cleaned, ensuring an optimum performance.



Convenient access

The engine and radiator covers have been designed to allow easy access. Sufficient space around the fuel tank opening makes the new mini excavator easier to refuel. The battery is positioned on the same side as the radiator for easy maintenance.

Quick cleaning

The undercarriage is easy to clean due to the soil-free truck structure from which accumulated mud and sand can be easily removed. Dozer blade openings help to minimise the build-up of dirt and make it quicker to remove.

Safety first

The battery disconnect switch is now available as standard for safer and easier maintenance.



The battery disconnect switch allows maintenance to be carried out safely.



Easy to open covers provide quick access.



Quick coupler port connection (optional) under toolbox allows for secure retrofit installation.



The tilting floor enables easy access to the engine and control valve for quick servicing.

SPECIFICATIONS

ENGINE

Model	4TNV88C
Type	4-cycle water-cooled, common rail direct injection
Aspiration	Coold EGR
Aftertreatment	Muffler filter
No. of cylinders	4
Rated power	
ISO 14396 : 2002	29.1 kW at 2 400 min ⁻¹
ISO 9249 : 2007	27.1 kW at 2 400 min ⁻¹
Maximum torque	135.8 Nm at 1 560 min ⁻¹
Piston displacement	2.189 L
Bore and stroke	88 mm x 90 mm
Battery	1 x 12 V / 72 Ah

HYDRAULIC SYSTEM

Hydraulic Pumps

Main pumps	1 variable displacement axial piston pump
Maximum oil flow	1 x 120 L/min
Pilot pump	1 gear pump
Maximum oil flow	12.0 L/min

Hydraulic Motors

Travel	2 variable displacement axial piston motors
Swing	1 axial piston motor

Relief Valve Settings

Implement circuit	24.5 MPa (250 kgf/cm ²)
Swing circuit	18.3 MPa (187 kgf/cm ²)
Travel circuit	24.5 MPa (250 kgf/cm ²)
Pilot circuit	6.7 MPa (68.3 kgf/cm ²)

Hydraulic Cylinders

	Quantity	Bore	Rod diameter	Stroke
Boom	1	90 mm	55 mm	699 mm
Arm	1	80 mm	50 mm	698 mm
Bucket	1	70 mm	40 mm	551 mm
Blade	1	105 mm	50 mm	140 mm
Boom swing	1	90 mm	50 mm	666 mm

UPPERSTRUCTURE

Revolving Frame

D-section frame for resistance to deformation.

Swing Device

Axial piston motor with planetary reduction gear is bathed in oil. Swing circle is single-row. Swing parking brake is spring-set/hydraulic-released disc type.

Swing speed	9.0 min ⁻¹ (rpm)
Swing torque	8.6 kNm (877 kgfm)

Operator's Cab

Independent spacious cab, 1 049 mm wide by 1 611 mm high, conforming to ISO* Standards. Reinforced glass windows on 4 sides for visibility. Front windows (upper and lower) can be opened. Reclining seat.
* International Organization for Standardization

AIR CONDITION SYSTEM

The air conditioning system contains fluorinated greenhouse gases.
Refrigerant type : HFC-134a, GWP : 1 430, Amount : 0.65 kg,
CO₂e: 0.93 ton

UNDERCARRIAGE

Tracks

Tractor-type undercarriage. Welded track frame using selected materials. Side frame welded to track frame.

Numbers of Rollers on Each Side

Upper roller	1
Lower rollers	4

Travel Device

Each track driven by 2-speed axial piston motor. Parking brake is spring-set/hydraulic-released disc type. Automatic transmission system: High-Low.

Travel speeds	High : 0 to 4.2 km/h
	Low : 0 to 2.5 km/h

Maximum traction force ... 38.3 kN (3 905 kgf)

Gradeability

58 % (30 degree) continuous

SOUND LEVEL

Sound level in cab according to ISO 6396 : 2008 LpA 75 dB(A)

External sound level according to ISO 6395 : 2008 and

EU Directive 2000/14/EC LwA 96 dB(A)

SERVICE REFILL CAPACITIES

Fuel tank	70.0 L
Engine coolant	4.7 L
Engine oil	7.4 L
Travel device (each side)	0.9 L
Hydraulic system	66.0 L
Hydraulic oil tank	42.0 L

WEIGHTS AND GROUND PRESSURE

Operating Weight and Ground Pressure

CAB

Shoe type	Shoe width	Arm length	kg	kPa (kgf/cm ²)
Rubber shoe	400 mm	1.38 m	4 850	26 (0.26)
		1.69 m	5 060*	27 (0.27)
Grouser shoe	400 mm	1.38 m	4 910	26 (0.27)
		1.69 m	5 120*	27 (0.28)
Pad crawler shoe	400 mm	1.38 m	4 970	26 (0.26)
		1.69 m	5 180*	27 (0.28)

Including 0.14 m³ (ISO 7451 : 2007 heaped), bucket weight (109 kg).

*Including 0.11 m³ (ISO 7451 : 2007 heaped), bucket weight (96 kg), additional counterweight (200 kg)

BUCKET AND ARM DIGGING FORCE

Arm length	1.38 m	1.69 m
Bucket digging force ISO 6015 : 2006	32.1 kN (3 270 kgf)	
Arm crowd force ISO 6015 : 2006	24.0 kN (2 450 kgf)	21.0 kN (2 140 kgf)

SPECIFICATIONS

WORKING RANGES

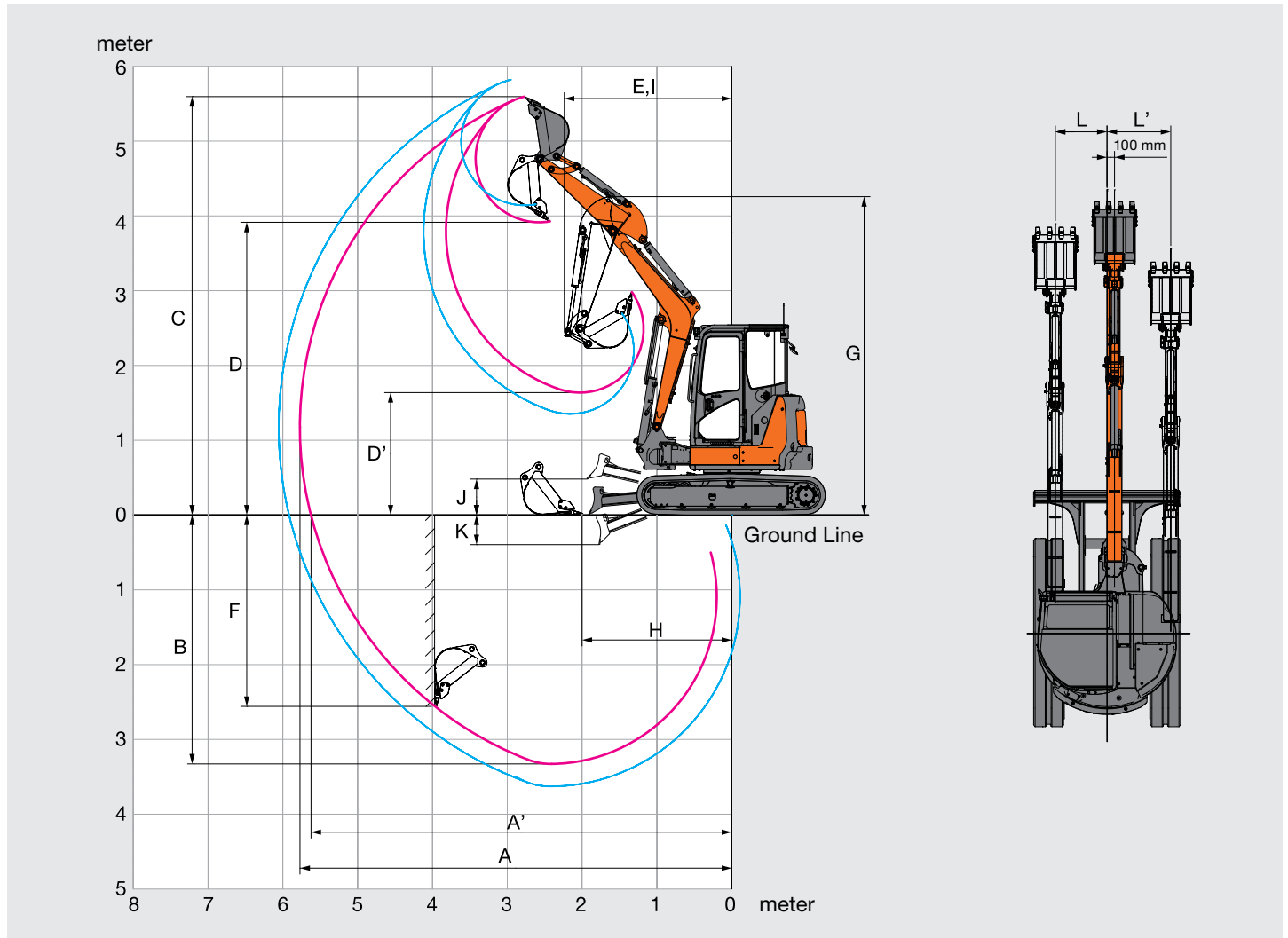

	Unit: mm	
Arm length	1.38 m	1.69 m
A Max. digging reach	5 760	6 060
A' Max. digging reach (on ground)	5 610	5 920
B Max. digging depth	3 320	3 630
C Max. cutting height	5 590	5 820
D Max. dumping height	3 910	4 140
D' Min. dumping height	1 630	1 350
E Min. swing radius	2 240	2 370
F Max. vertical wall digging depth	2 550	2 880
G Front height at Min. swing radius	4 250	4 250
H Min. level crowding distance	2 000	1 870
I Working radius at Min. swing radius (Max. boom-swing angle)	1 750	1 860
J Blade bottom highest position above ground	480	480
K Blade bottom lowest position above ground	395	395
L/L' Offset distance (Max. boom-swing angle)	690 / 850	690 / 850
Max. boom-swing angle (deg.)	80 / 60	80 / 60

DIMENSIONS

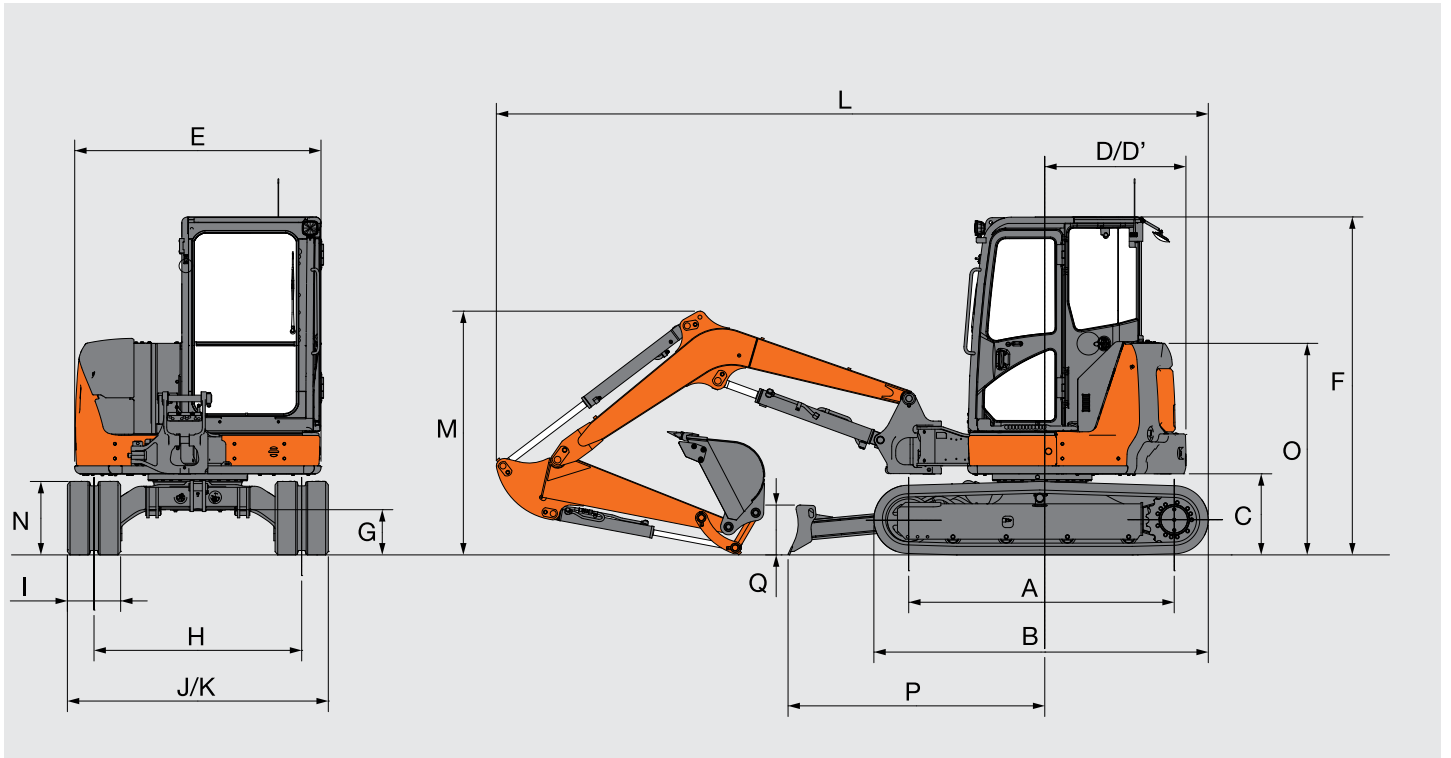

Unit: mm

	ZAXIS 48U
A Distance between tumblers	2 000 (1 990)
B Undercarriage length	2 500 (2 490)
*C Counterweight clearance	610 (590)
D Rear-end swing radius	980 (1 080 with additional counterweight)
D' Rear-end length	980 (1 080 with additional counterweight)
E Overall width of upperstructure	1 850
F Overall height of cab	2 530
*G Min. ground clearance	340 (320)
H Track gauge	1 560
I Track shoe width	400
J Undercarriage width	1 960
K Overall width (Blade width)	1 960
L Overall length	
With 1.38 m arm	5 350
With 1.69 m arm	5 390
*M Overall height of boom	
With 1.38 m arm	1 840
With 1.69 m arm	2 035
N Track height	550 (530)
O Engine cover-height	1 590 (1 570)
P Horizontal distance to blade	1 910
Q Blade height	375

* Excluding track shoe lug Data in () are dimensions of grouser shoe.

MACHINE CAPACITIES

- Notes:
1. Ratings are based on ISO 10567 : 2007.
 2. Machine capacity does not exceed 75% of tipping load with the machine on firm, level ground or 87% full hydraulic capacity.
 3. The load point is the center-line of the bucket pivot mounting pin on the arm.
 4. *Indicates load limited by hydraulic capacity.
 5. 0 m = Ground.

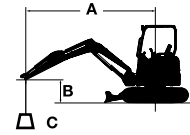

- A: Load radius
B: Load point height
C: Lifting capacity

To determine lifting capacities, apply "Rating over-side or 360 degrees" machine capacities from the table and deduct weight of installed attachment and quick coupler.
Optional feature may affect machine performance.

ZAXIS 48U Cab Version, Blade above Ground

Rating over-front Rating over-side or 360 degrees Unit : 1 000 kg

Conditions	Load point height m	Load radius										At max. reach		
		1.0 m		2.0 m		3.0 m		4.0 m		5.0 m				meter
Boom 2.68 m Arm 1.69 m Additional counterweight 200 kg Rubber shoe 400 mm	3.0							*0.99	0.87			0.79	0.65	4.80
	2.0					*1.46	1.30	1.03	0.84	0.73	0.60	0.70	0.57	5.13
	1.0					1.53	1.26	0.99	0.80	0.71	0.58	0.67	0.55	5.21
	0 (Ground)					1.47	1.16	0.96	0.77	0.70	0.57	0.70	0.57	5.04
	-1.0	*1.93	*1.93	*2.59	2.20	1.46	1.15	0.96	0.77			0.79	0.64	4.60
	-2.0			*2.66	2.25	1.49	1.17					1.07	0.86	3.76

ZAXIS 48U Cab Version, Blade above Ground

Rating over-front Rating over-side or 360 degrees Unit : 1 000 kg

Conditions	Load point height m	Load radius										At max. reach		
		1.0 m		2.0 m		3.0 m		4.0 m		5.0 m				meter
Boom 2.68 m Arm 1.38 m Rubber shoe 400 mm	3.0					1.19	1.20	0.96	0.78			0.80	0.65	4.47
	2.0					1.46	1.16	0.93	0.76			0.70	0.57	4.83
	1.0					1.38	1.08	0.90	0.72			0.67	0.54	4.91
	0 (Ground)					1.34	1.05	0.88	0.70			0.70	0.56	4.73
	-1.0			2.78	2.02	1.34	1.05	0.88	0.70			0.81	0.65	4.25
	-2.0			*2.07	*2.07	*1.33	1.08					*1.11	0.95	3.29

EQUIPMENT

● : Standard equipment

○ : Optional equipment

ENGINE

Air cleaner double filters	○
Alternator 12V - 55 A	●
Auto idle system	●
Cartridge-type engine oil filter	●
Cartridge-type fuel main filter	●
Dust-proof indoor net	○
ECO/PWR mode control	●
Electrical fuel feed pump	●
Fuel cooler	●
Fuel pre-filter with water separator	●
Radiator reserve tank	●

HYDRAULIC SYSTEM

Boom anti-drift valve	●
Full-flow filter	●
Hydraulic pilot type control levers	●
Pilot control shut-off lever with neutral engine start system	●
Pilot filter	●
Suction filter	●
Swing parking brake	●
Travel parking brake	●
Two-speed travel system	●
Valve for extra piping	●

CAB

Air conditioner*	●
AM/FM radio	●
Anti-slip plate	●
Armrest	●
Defroster (Front, Rear)	●
Drink holder	●
Electric horn	●
Front window power-assisted with gas damper	●
Floor mat	●
Heater	●
OPG top guard, Level I (ISO 10262 : 1998) compliant cab	●
Retractable seat belt	●
ROPS (ISO 12117-2 : 2008 + A1 : 2016) compliant cab	●
Seat with height adjustment	●
Spare power supply 12V (inside)	●
Spare power supply 12V (outside)	○
Sun visor (front window (rigid type))	○
Suspension seat with reclining (fabric)	●
Window washer	●
Wiper (Front, Rear)	●

LIGHTS

Additional cab roof front lights	○
3 working LED lights (Boom x 1, cab roof front x 2)	●

UPPER STRUCTURE

Auxiliary flow rate selector	○
Auxiliary function lever (AFL)	○
Auxiliary overload relief valve	○
Batteries 1 x 70 Ah	●
Batteries 1 x 92 Ah***	○
Battery disconnect switch	●
Electric refuel pump	○
GSM mobile communication system***	●
Pilot accumulator	○
Rearview mirror	●
Tool box	●
200 kg additional counterweight	○

UNDERCARRIAGE

400 mm grouser shoe	○
400 mm pad crawler shoe	○
400 mm rubber shoe	●

FRONT ATTACHMENTS

Assist piping	○
Extra piping	●
HN bushing	●
Hose rupture valve for arm	●
Hose rupture valve for boom	●
1.38 m arm	○
1.69 m arm	●

MISCELLANEOUS

Global e-Service***	○
Theft deterrent system**	○

Standard and optional equipment may vary by country, so please consult authorized dealer for details.

* Contains fluorinated greenhouse gases, Refrigerant type: HFC-134a, GWP: 1430, Amount: 0.65 kg, CO₂e: 0.93 ton.

** Hitachi Construction Machinery cannot be held liable for theft, any system will just minimize the risk of theft.

*** It is possible to obtain information by connecting to Global e-service with a Hitachi genuine mobile terminal.

Prior to operating this machine, including satellite communication system, in a country other than a country of its intended use, it may be necessary to make modifications to it so that it complies with the local regulatory standards (including safety standards) and legal requirements of that particular country. Please do not export or operate this machine outside the country of its intended use until such compliance has been confirmed. Please contact authorized dealer in case of questions about compliance.

These specifications are subject to change without notice. Illustrations and photos show the standard models, and may or may not include the latest feature updates, optional equipment, accessories, and all standard equipment with some differences in colour and features. Before use, read and understand the Operator's Manual for proper operation.

