

ZAXIS65USB



Notes: Standard and optional equipment may vary by country, please consult your Hitachi dealer for details. The machines shown on this brochure are so positioned for the sake of demonstrations. When leaving the machine, be sure to rest the bucket on the ground.

HYDRAULIC EXCAVATOR

Model Code : ZX65USB-5A

Engine Rated Power : 34.1 kW (45.7 HP)

Operating Weight : 6 170 - 6 600 kg

Backhoe Bucket : ISO Heaped : 0.21 m³

Trustworthy and User-Friendly New Compact Excavators

The new series of Hitachi compact excavators has evolved even more. We listen to customers' needs, provide solutions, and adopt fresh ideas into our new products.

The outcome is new excavators that are compact, productive and nimble.

The round body is smart and its wide-opening covers provide direct access to service points for quick maintenance.

The operator station is full of easy-to-use controls, an informative multi-monitor, and comfortable operator seat. A low fuel consumption design ensures better fuel efficiency.

ZAXIS Empower your Vision.

HIGH PERFORMANCE

- Swift actions in narrow work place
- Excellent controllability
- Reduced fuel consumption

OPERATOR COMFORT

- Pleasant operator environment
- Sturdy operator stations by rigorous safety standards
- Easy-to-read multi-monitor

SIMPLIFIED MAINTENANCE

- Open-wide covers for easy maintenance
- Easy to clean cab floor

DURABILITY

- A line of Hitachi quality products
- Strong front attachment
- Rugged box-section blade
- Sturdy upperstructure



Shown equipped with 1.85 m arm, extra piping, additional counterweight, and pre-cleaner.

Notes: Standard and optional equipment may vary by country, so please consult your Hitachi dealer for details.

HIGH PERFORMANCE

Agility Stands for Efficiency

Swift Actions in Narrow Work Place

Short rear-end swing design allows for safe, confident operation in tight work areas.



Shown equipped with 1.85 m arm, extra piping, and pre-cleaner.



Excellent Controllability

The Hitachi pilot control system is impressive. Its pilot lever provides excellent fine control and low-effort handling to reduce operator fatigue. It is ergonomically positioned for easy operation. The HHH (Hitachi High-performance Hydraulic) system allows for smooth operation by lever control regardless of the load. The multi-monitor allows selection of ECO and PWR modes to control the motion speed. With the engine control dial, you can also adjust engine speed with ease. The auto speed change system shifts down travel speed when the load exceeds a certain limit (for instance, when going downhill), and shifts up when the load is less.



Control lever



Engine control dial

ECO / PWR mode selector switch



Reduced Fuel Consumption

A new engine has an electronic governor that is a clue to low fuel consumption. With an electronic accelerator, you can achieve precision engine control for fuel economy. To conserve fuel, select ECO mode, and to get more power, select PWR mode. In short, you can choose an optimum mode according to job needs. The Auto Idle helps save fuel consumption, too. When moving the control lever to neutral, the Auto Idle automatically reduces engine speed to idling level four seconds later, reducing fuel consumption.

OPERATOR COMFORT

Comfortable Operator Stations to Yield High Production



Pleasant Operator Environment

Hitachi cabs have been traditionally praised for operator comfort. They are spacious with ample leg room. The console and seat are designed ergonomically, standing for operator comfort. When sitting in the operator station, the operator will not feel restricted. Cab door width increases by 80 mm for easy access and a better view of work place. The front windshield is enlarged for higher visibility. The foot step is lowered for easy access. A host of devices, including armrests, drink holder and seat back box, enhance operator comfort.

Sturdy Operator Stations by Rigorous Safety Standards

The rugged cab well protect the operator in case of tipping. They are ruggedly designed by the ROPS* standard. All the models are protected with the OPG** top guard against falling objects. A seat belt, pilot control shut-off lever, swing parking brake and travel parking brake are all standard. The neutral engine start system further enhances safe operation, disabling engine starting unless the lever is in lock position.

*Roll-Over Protection Structure
**Operator Protection Guard

Easy-to-Read Multi-Monitor

The multi-monitor is bright, informative and easy-to-read, displaying machine conditions, settings and warnings. A clock is newly added.

- 1 Menu/Return Switch
- 2 Auto-Idle Selector Switch
- 3 ECO/PWR Mode Selector Switch

Items

- Coolant Temperature Gauge
- Fuel Gauge
- Hour Meter
- Clock
- Travel Mode Indicator
- Work Light Indicator
- Overheat Indicator
- Engine Oil Pressure Indicator
- Preheat Indicator
- Fuel Level Indicator

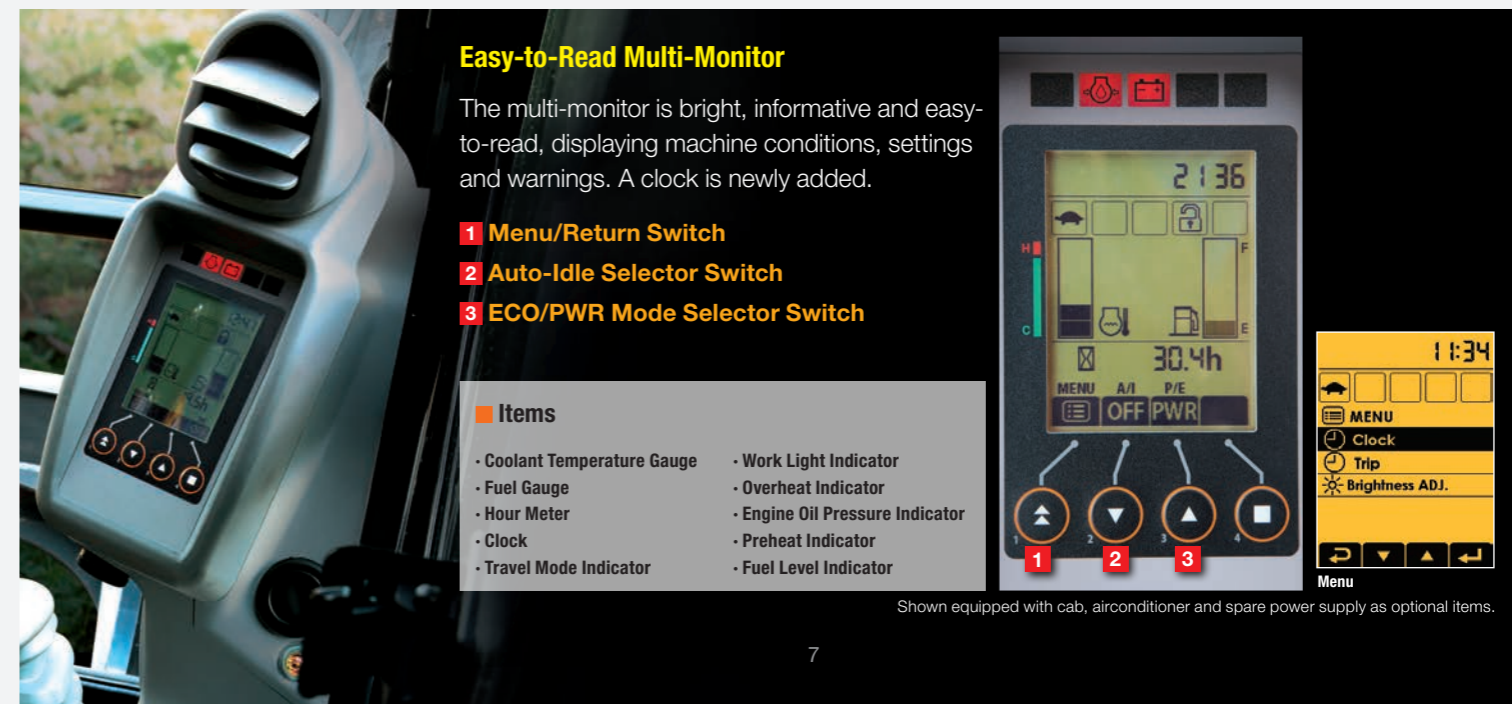

Shown equipped with cab, airconditioner and spare power supply as optional items.

SIMPLIFIED MAINTENANCE

Easy Servicing, Day-in Day-out

Open-Wide Covers for Easy Maintenance

All covers are wide-opening for direct access to service points, allowing for quick daily inspection and replacement. A cover adjacent to the radiator extends vertically to easily clean the radiator. A refueling port is placed inside the cover to avoid dirt entry and fuel theft. A new tank cover is lightweight and wide-opening for easy refueling. A large tool box is located beside the operator seat to store a grease gun and the likes. All this increases uptime.

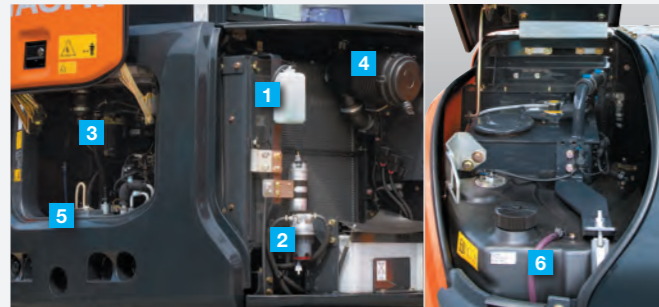

- 1 Reserve tank
- 2 Water separator
- 3 Fuel filter
- 4 Air filter
- 5 Engine oil filter
- 6 Fuel tank



Easy-to-Clean Cab Floor

The radiator and oil cooler are arranged in parallel, instead of conventional in-line arrangement, to promote easy, efficient cleaning and cooling. Their wavy fins can be easily cleaned by air blowing. Dust-proof indoor nets are standard for easy removal of debris and dirt. A split-type floor mat can easily be removed at a seam between foot pedals and cab floor, and its surface patterns allow for quick sweeping.

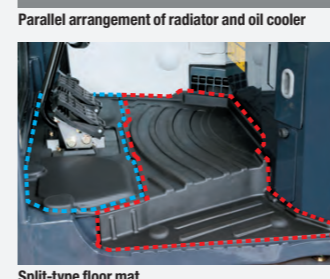
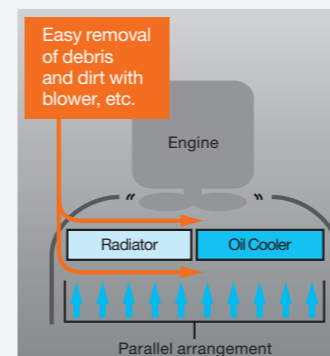

Shown equipped with 1.85 m arm, extra piping, and pre-cleaner.

DURABILITY

Technological Prowess and Stringent Quality Control

A Line of Hitachi Quality Products

Hitachi has been acclaimed worldwide for technological prowess and high-performance products since the launch of its first hydraulic excavator in 1949. Its Design Division has adopted the 3D-CAD system for applied analysis and data crunching to churn out quality products and slash lead time in development.

Newly developed products have been vigorously tested in multiple ways, such as long-hours durability test and evaluation test, at a Hitachi vast 427 hectares test field under critical operating conditions – for instance, tropical or freezing weather -- before unveiling new products.



Strong Front Attachment

Front pins are jointed with a tight fit to reduce jerking and noise significantly, enhancing durability. Those pins are lubricated with HN bushings having an abundant grease-retaining capacity, extending greasing intervals up to 500 hours.

Main hoses are sheathed with hose protectors at the swing post. The bottom side of the boom cylinder is protected with a V-shaped boom cylinder guard. The four-side reinforced arm is sturdy with high rigidity.

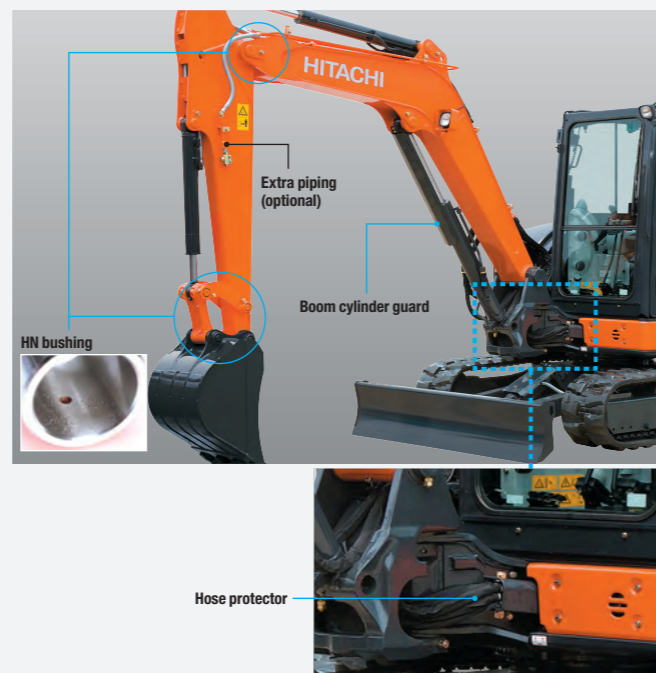

Rugged Box-Section Blade

The blade is box-section structure for higher ruggedness, and its stays have openings for easy flow-out of mud.



Box-section blade



D-section frame skirt

Sturdy Upperstructure

The upperstructure frame is reinforced with job-proven D-section skirts whose height is increased for larger cross section to boost durability against obstacles.



SPECIFICATIONS

ENGINE

Model	Yanmar 4TNV94L-ZWHB
Type	4-cycle water-cooled, direct injection
No. of cylinders	4
Rated power	
ISO 9249, net	34.1 kW (45.7 HP) at 2 000 min ⁻¹ (rpm)
EEC 80/1269, net	34.1 kW (45.7 HP) at 2 000 min ⁻¹ (rpm)
SAE J1349, net	34.1 kW (45.7 HP) at 2 000 min ⁻¹ (rpm)
Maximum torque	204 Nm (20.8 kgfm) at 1 000 min ⁻¹ (rpm)
Piston displacement	3.053 L
Bore and stroke	94 mm x 110 mm
Batteries	1 x 12 V / 92 Ah

HYDRAULIC SYSTEM

Hydraulic pumps

Main pumps	1 variable displacement axial piston pumps
Maximum oil flow	1 x 144 L/min
Pilot pump	1 gear pump
Maximum oil flow	10.4 L/min

Hydraulic Motors

Travel	2 variable displacement axial piston motors
Swing	1 axial piston motor

Relief Valve Settings

Implement circuit	24.5 MPa (250 kgf/cm ²)
Swing circuit	19.6 MPa (200 kgf/cm ²)
Travel circuit	25.7 MPa (262 kgf/cm ²)
Pilot circuit	3.9 MPa (40 kgf/cm ²)

Hydraulic Cylinders

	Quantity	Bore	Rod diameter	Stroke
Boom	1	110 mm	60 mm	785 mm
Arm	1	90 mm	55 mm	770 mm
Bucket	1	80 mm	50 mm	581 mm
Blade	1	120 mm	70 mm	135 mm
Boom swing	1	95 mm	55 mm	710 mm

UPPERSTRUCTURE

Revolving Frame

D-section frame for resistance to deformation.

Swing Device

Axial piston motor with planetary reduction gear is bathed in oil. Swing circle is single-row. Swing parking brake is spring-set/hydraulic-released disc type.

Swing speed	9.5 min ⁻¹ (rpm)
Swing torque	11.0 kNm (1 120 kgfm)

Operator's Cab

Independent spacious cab, 1 050 mm wide by 1 610 mm high, conforming to ISO* Standards. Reinforced glass windows on 4 sides for visibility. Front windows (upper and lower) can be opened. Reclining seat.

* International Organization for Standardization

UNDERCARRIAGE

Tracks

Tractor-type undercarriage. Welded track frame using selected materials. Side frame welded to track frame.

Numbers of Rollers on Each Side

Upper roller	1
Lower rollers	4

Travel Device

Each track driven by 2-speed axial piston motor. Parking brake is spring-set/hydraulic-released disc type. Automatic transmission system: High-Low.

Travel speeds	High : 0 to 4.8 km/h
	Low : 0 to 2.9 km/h

Maximum traction force . 39.8 kN (4 060 kgf)

Gradeability

58 % (30 degree) continuous

SERVICE REFILL CAPACITIES

Fuel tank	120.0 L
Engine coolant	7.4 L
Engine oil	11.2 L
Travel device (each side)	0.9 L
Hydraulic system	108.0 L
Hydraulic oil tank	60.0 L

WEIGHTS AND GROUND PRESSURE

Operating Weight and Ground Pressure

Shoe type	Shoe width	Arm length	kg	kPa (kgf/cm ²)
Rubber shoes	400 mm	1.50 m	6 170	35 (0.36)
		1.85 m	6 470*	37 (0.37)*
Grouser shoes	400 mm	1.50 m	6 270	35 (0.36)
		1.85 m	6 570*	37 (0.38)*
Pad crawler shoes	400 mm	1.50 m	6 300	36 (0.36)
		1.85 m	6 600*	37 (0.38)*

Including 0.21 m³ (ISO heaped), bucket weight (146 kg).

* Including 0.20 m³ (ISO heaped), bucket weight (138 kg), additional counterweight (270 kg).

BUCKET AND ARM DIGGING FORCE

Arm length	1.50 m	1.85 m
Bucket digging force ISO	41.1 kN (4 190 kgf)	
Bucket digging force SAE : PCSA	35.9 kN (3 660 kgf)	
Arm crowd force ISO	31.1 kN (3 170 kgf)	27.0 kN (2 750 kgf)
Arm crowd force SAE : PCSA	29.5 kN (3 010 kgf)	25.8 kN (2 630 kgf)

WORKING RANGES

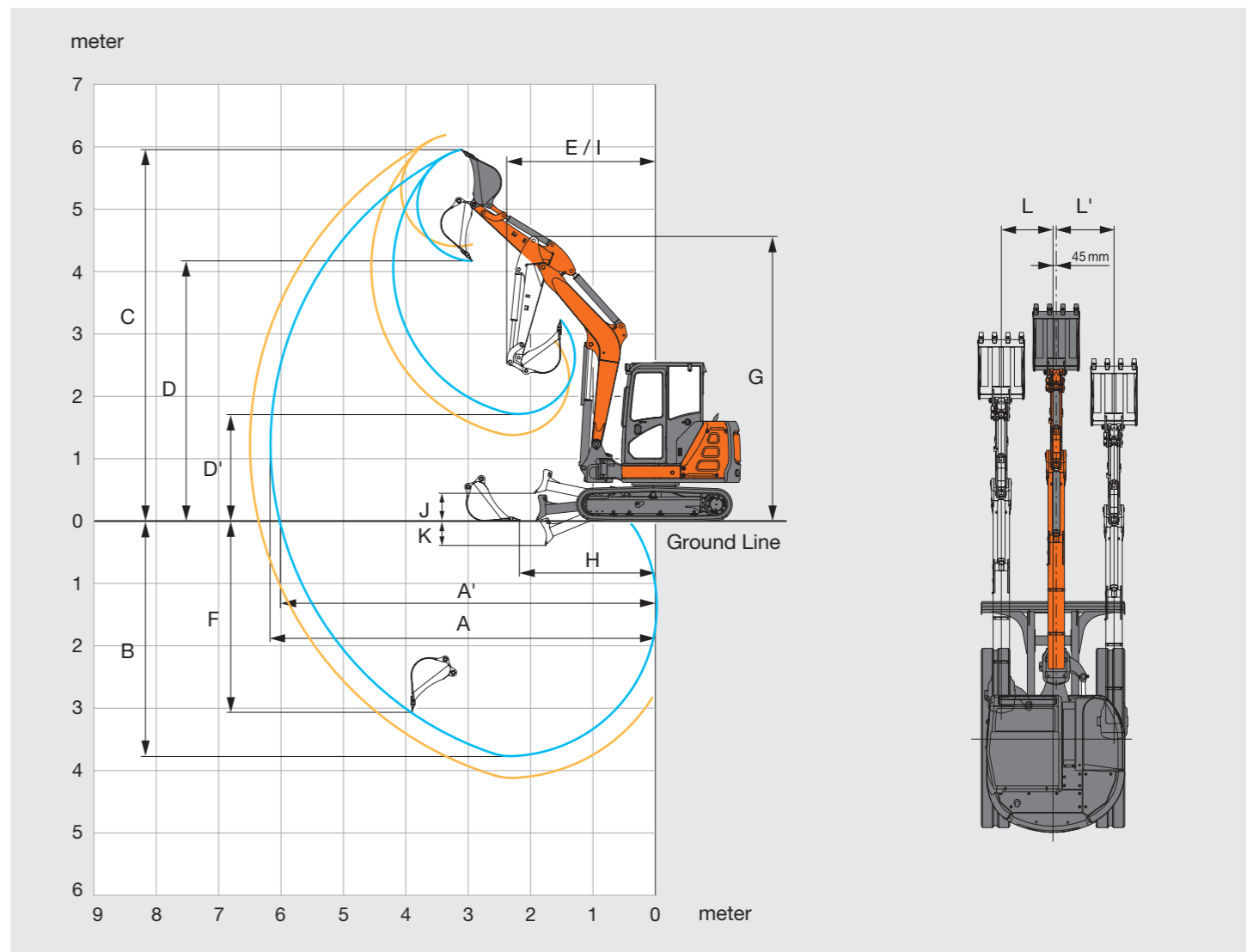

Unit: mm

Arm length	1.50 m	1.85 m
A Max. digging reach	6 230	6 560
A' Max. digging reach (on ground)	6 080	6 420
B Max. digging depth	3 770	4 120
C Max. cutting height	5 960	6 190
D Max. dumping height	4 170	4 410
D' Min. dumping height	1 720	1 380
E Min. swing radius	2 450	2 540
F Max. vertical wall digging depth	3 050	3 390
G Front height at Min. swing radius	4 560	4 560
H Min. level crowding distance	2 170	2 000
I Working radius at Min. swing radius (Max. boom-swing angle)	1 980	2 060
J Blade bottom highest position above ground	450	450
K Blade bottom lowest position above ground	390	390
L/L' Offset distance	720 / 850	720 / 850
Max. boom-swing angle (deg.)	80 / 60	80 / 60

Excluding track shoe lug.

SPECIFICATIONS

DIMENSIONS

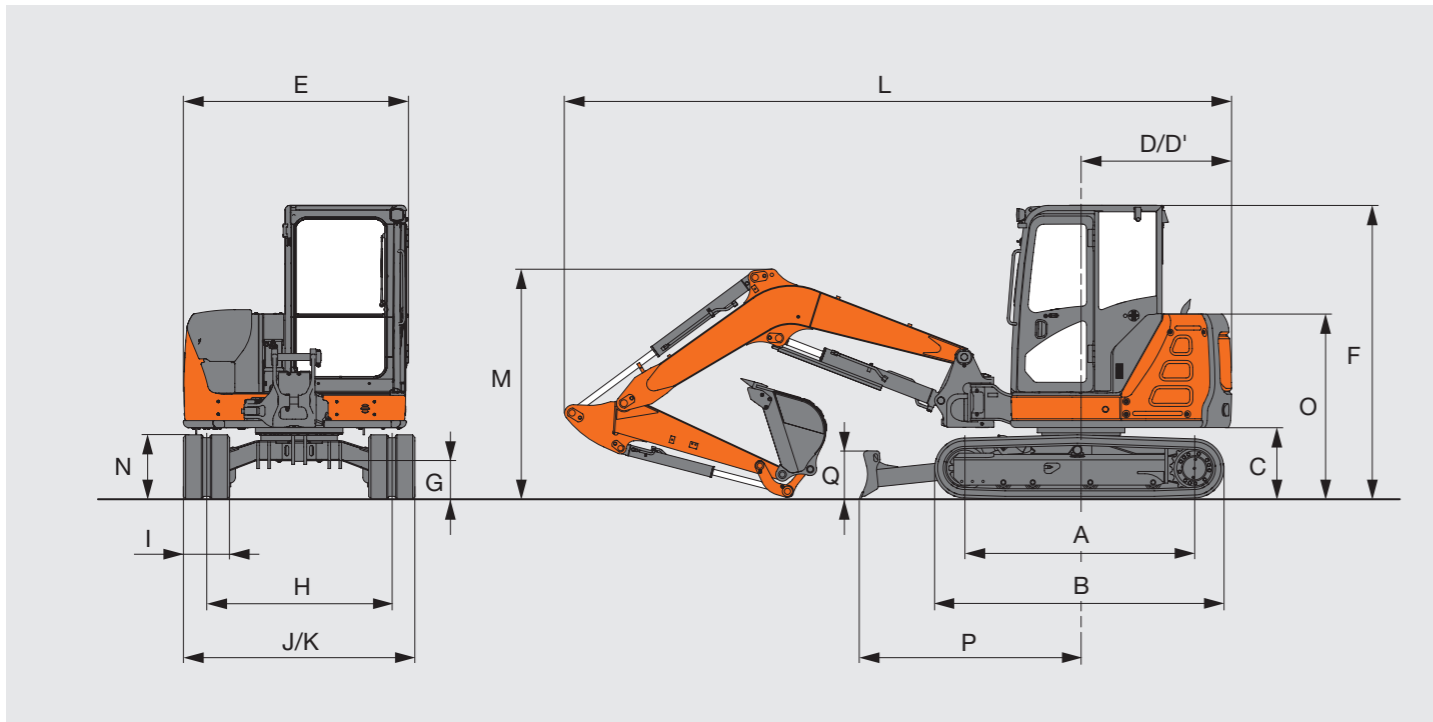

Unit: mm

	ZX65USB-5A
A Distance between tumblers	1 990
B Undercarriage length	2 500
* C Counterweight clearance	620
D Rear-end swing radius	1 300 (1 410)
D' Rear-end length	1 300 (1 410)
E Overall width of upperstructure	1 930
F Overall height of cab	2 540
* G Min. ground clearance	335
H Track gauge	1 600
I Track shoe width	400
J Undercarriage width	2 000
K Overall width (Blade width)	2 000
L Overall length	
With 1.50 m arm	5 760 (5 870)
With 1.85 m arm	5 790 (5 900)
* M Overall height of boom	
With 1.50 m arm	1 980
With 1.85 m arm	2 170
N Track height	560
O Engine cover-height	1 600
P Horizontal distance to blade	1 920
Q Blade height	420

* Excluding track shoe lug Data in () are dimensions of additional counterweight.

MACHINE CAPACITIES

- Notes:
1. Ratings are based on ISO 10567 : 2007.
 2. Machine capacity does not exceed 75% of tipping load with the machine on firm, level ground or 87% full hydraulic capacity.
 3. The load point is the center-line of the bucket pivot mounting pin on the arm.
 4. *Indicates load limited by hydraulic capacity.
 5. 0 m = Ground.

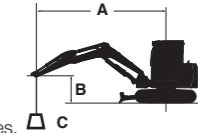

A: Load radius
B: Load point height
C: Lifting capacity

For machine capacities, subtract installed attachment and quick hitch weight from machine capacities. To determine lifting capacities, apply "Rating over-side or 360 degrees" machine capacities from the table and deduct weight of installed attachment and quick hitch. Optional feature may affect machine performance.

ZX65USB-5A, Blade above Ground

Rating over-front Rating over-side or 360 degrees Unit : 1 000 kg

Conditions	Load point height m	Load radius										At max. reach		
		1.0 m		2.0 m		3.0 m		4.0 m		5.0 m		meter		
		Rating over-front	Rating over-side or 360 degrees	Rating over-front	Rating over-side or 360 degrees	Rating over-front	Rating over-side or 360 degrees	Rating over-front	Rating over-side or 360 degrees	Rating over-front	Rating over-side or 360 degrees			
Boom 2.97 m	4.0							*1.29	*1.29			1.16	0.99	4.74
Arm 1.85 m	3.0							*1.42	1.29	1.06	0.90	0.95	0.82	5.30
Additional counterweight 270 kg	2.0					2.28	1.90	1.45	1.23	1.03	0.88	0.86	0.74	5.59
Rubber shoe 400 mm	1.0					2.11	1.74	1.38	1.17	1.00	0.85	0.84	0.71	5.65
	0 (Ground)					2.03	1.66	1.33	1.12	0.98	0.83	0.86	0.73	5.48
	-1.0	*2.07	*2.07	*2.64	*2.64	2.01	1.65	1.32	1.10	0.97	0.82	0.95	0.81	5.08
	-2.0	*3.37	*3.37	4.24	3.25	2.04	1.68	1.33	1.12			1.20	1.01	4.34
	-3.0			*2.97	*2.97							*1.79	*1.79	2.93

ZX65USB-5A, Blade on Ground

Rating over-front Rating over-side or 360 degrees Unit : 1 000 kg

Conditions	Load point height m	Load radius										At max. reach		
		1.0 m		2.0 m		3.0 m		4.0 m		5.0 m		meter		
		Rating over-front	Rating over-side or 360 degrees	Rating over-front	Rating over-side or 360 degrees	Rating over-front	Rating over-side or 360 degrees	Rating over-front	Rating over-side or 360 degrees	Rating over-front	Rating over-side or 360 degrees			
Boom 2.97 m	4.0							*1.29	*1.29			*1.37	0.99	4.74
Arm 1.85 m	3.0							*1.42	1.29	*1.45	0.90	*1.30	0.82	5.30
Additional counterweight 270 kg	2.0					*2.31	1.90	*1.78	1.23	*1.57	0.88	*1.32	0.74	5.59
Rubber shoe 400 mm	1.0					*3.34	1.74	*2.19	1.17	*1.75	0.85	*1.41	0.71	5.65
	0 (Ground)					*3.81	1.66	*2.47	1.12	*1.87	0.83	*1.59	0.73	5.48
	-1.0	*2.07	*2.07	*2.64	*2.64	*3.75	1.65	*2.51	1.10	*1.80	0.82	*1.75	0.81	5.08
	-2.0	*3.37	*3.37	*4.58	3.25	*3.23	1.68	*2.15	1.12			*1.83	1.01	4.34
	-3.0			*2.97	*2.97							*1.79	*1.79	2.93

ZX65USB-5A, Blade above Ground

Rating over-front Rating over-side or 360 degrees Unit : 1 000 kg

Conditions	Load point height m	Load radius										At max. reach		
		1.0 m		2.0 m		3.0 m		4.0 m		5.0 m		meter		
		Rating over-front	Rating over-side or 360 degrees	Rating over-front	Rating over-side or 360 degrees	Rating over-front	Rating over-side or 360 degrees	Rating over-front	Rating over-side or 360 degrees	Rating over-front	Rating over-side or 360 degrees			
Boom 2.97 m	4.0							1.37	1.16			1.20	1.02	4.32
Arm 1.50 m	3.0					*1.78	*1.78	1.35	1.15			0.95	0.81	4.95
Rubber shoe 400 mm	2.0					2.01	1.66	1.29	1.09	0.92	0.78	0.85	0.72	5.26
	1.0					1.87	1.53	1.23	1.03	0.89	0.76	0.82	0.69	5.32
	0 (Ground)					1.82	1.48	1.20	1.00	0.88	0.74	0.85	0.71	5.14
	-1.0	*2.58	*2.58	*3.07	2.90	1.82	1.49	1.19	0.99			0.96	0.81	4.70
	-2.0			3.88	2.97	1.86	1.53					1.28	1.07	3.87

ZX65USB-5A, Blade on Ground

Rating over-front Rating over-side or 360 degrees Unit : 1 000 kg

Conditions	Load point height m	Load radius										At max. reach		
		1.0 m		2.0 m		3.0 m		4.0 m		5.0 m		meter		
		Rating over-front	Rating over-side or 360 degrees	Rating over-front	Rating over-side or 360 degrees	Rating over-front	Rating over-side or 360 degrees	Rating over-front	Rating over-side or 360 degrees	Rating over-front	Rating over-side or 360 degrees			
Boom 2.97 m	4.0							*1.55	1.16			*1.62	1.02	4.32
Arm 1.50 m	3.0					*1.78	*1.78	*1.64	1.15			*1.64	0.81	4.95
Rubber shoe 400 mm	2.0					*2.74	1.66	*1.98	1.09	*1.71	0.78	*1.67	0.72	5.26
	1.0					*3.64	1.53	*2.35	1.03	*1.84	0.76	*1.75	0.69	5.32
	0 (Ground)					*3.87	1.48	*2.55	1.00	*1.90	0.74	*1.82	0.71	5.14
	-1.0	*2.58	*2.58	*3.07	2.90	*3.63	1.49	*2.47	0.99			*1.91	0.81	4.70
	-2.0			*4.67	2.97	*2.91	1.53					*1.96	1.07	3.87

EQUIPMENT

Standard and optional equipment may vary by country, so please consult your Hitachi dealer for details.

● : Standard equipment

○ : Optional equipment

ENGINE	CAB	LIGHTS	FRONT ATTACHMENTS
Auto idle system ●	AM/FM radio ●	Auxiliary light ○	Extra piping ○
Cartridge-type engine oil filter ●	Armrests ●		HN bushing ●
Dust-proof indoor net ●	Auxiliary function lever (AFL) ○		Hose rupture valve ○
ECO/PWR mode control ●	Defroster ●	UPPERSTRUCTURE	Pilot accumulator ○
Electrical fuel feed pump ●	Drink holder ●	Electric fuel refilling pump ○	1.50 m arm ●
Fuel main filter ●	Fresh air introduction type air conditioner ●	Tool box ●	1.50 m 4-side reinforced arm ○
High performance water separator ●	Pilot control shutt-off lever with neutral engine start system ●	270 kg additional counterweight ○	1.85 m arm ○
Pre-cleaner ○	Rearview mirror ●		1.85 m 4-side reinforced arm ○
Radiator, oil cooler ●	Reclining seat ●	UNDERCARRIAGE	
Radiator reserve tank ●	Retractable seat belt ●	Travel parking brake ●	MISCELLANEOUS
55 A alternator ●	ROPS/OPG cab ●	400 mm grouser shoes ○	Theft deterrent system* ○
	Spare power supply ●	400 mm pad crawler shoes ○	
HYDRAULIC SYSTEM	Suspension seat ●	400 mm rubber shoes ●	
Auxiliary flow rate selector ○	Window washer ●		
Hydraulic pilot type control levers ●	Wiper ●		
Swing parking brake ●			
Travel parking brake ●			
Two-speed travel system ●			

* Hitachi Construction Machinery cannot be held liable for theft, any system will just minimize the risk of theft.

These specifications are subject to change without notice.

Illustrations and photos show the standard models, and may or may not include optional equipment, accessories, and all standard equipment with some differences in color and features.

Before use, read and understand the Operator's Manual for proper operation.

